

# Directly mounted CAN controls

Proportional directional spool valve type PSL and PSV (sandwich styles)

Proportional directional spool valve type PSLF and PSVF (manifold mounting)

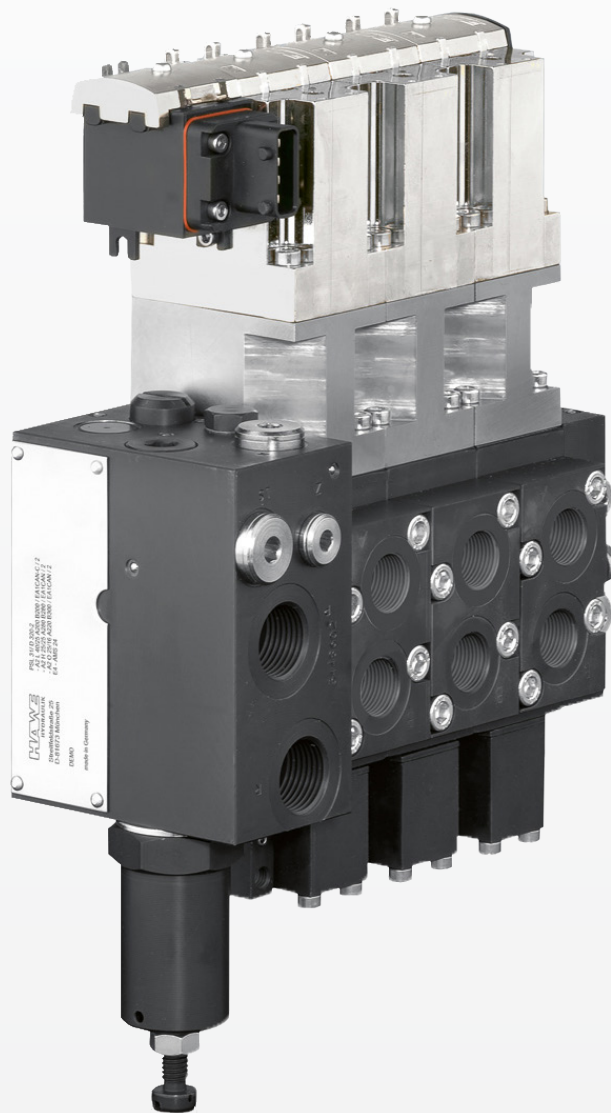

Solutions for a World under Pressure

**HAWE**  
HYDRAULIK

## Directly mounted CAN controls for proportional directional spool valves

Proportional directional spool valve banks are used to control the direction of movement and the infinite adjustment of the movement speed of the hydraulic consumers independent of the load. This allows multiple consumers to be run at the same time and independently of each other at different speeds and pressures, as long as the sum of the partial flow rates required for this is covered by the total delivery flow on the pump side. The electrical connection between the valve sections is via internal cable connections (power supply and CAN bus).

### Features and benefits:

- Simple wiring
- In-built displacement transducer
- Calibrated at the factory ( $i_{min}$ ,  $i_{max}$ , etc.)
- Configurable valve characteristics (linearisation, precision control ranges etc.)
- Adjustable ramps
- Increased response characteristics
- Ability to limit maximum flow rate
- Diagnostic capability (fault detection, spool position)
- Compensated and uncompensated basic modules
- Check valve
- Shock valves
- Hydraulic actuation

### Intended applications:

- Cranes
- Hydraulic steering systems
- Construction machines
- Lifting devices
- Machines for forestry purposes
- Municipal trucks

### Versions:

- Actuation option for sizes 2, 3 and 5 (sandwich style)
- Actuation option for sizes 3 and 7 (manifold mounting)

### Available spools:

- Closed or open neutral position
- Asymmetrical flow options
- Electrical, mechanical or hydraulic actuation

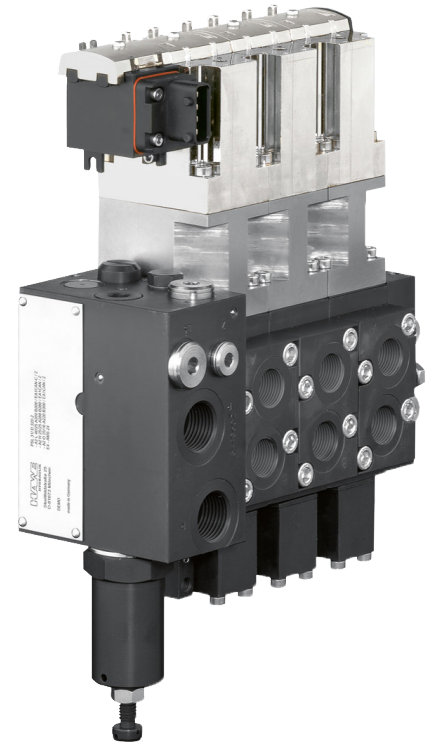

<b>Nomenclature:</b>	Prop. directional spool valve as per load-sensing principle
<b>Actuation:</b>	Manual <ul style="list-style-type: none"> <li>■ Return spring</li> <li>■ Detent</li> </ul> Electro-hydraulic Pressure-actuated <ul style="list-style-type: none"> <li>■ Hydraulic</li> <li>■ Pneumatic</li> </ul>
<b><math>p_{max}</math>:</b>	400 bar
<b><math>Q_{max\ consumer}</math>:</b>	240 l/min
<b><math>Q_{pu\ max}</math>:</b>	approx. 300 lpm

# Technical data

## Electrical parameters

Operating voltage $U_B$	12 to 30 V DC
Max. operating current	10 A (CAN connection base)
Current consumption $I_V$	Max. 800 mA at $U_B = 24$ V DC (per valve section) Max. 1.5 A at $U_B = 12$ V DC (per valve section)

## Communication

CAN protocol	CANopen, J 1939
CAN bit rate	10 ... 1000 kbit/s
CAN-ID	1 ... 127

## Dimensions (All dimensions in mm, subject to change)

SIZE 2  
(sandwich style)

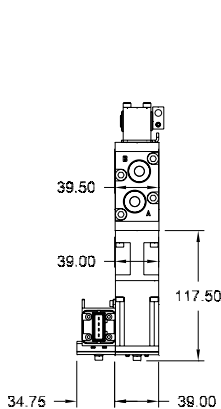

Size 3  
(sandwich style)

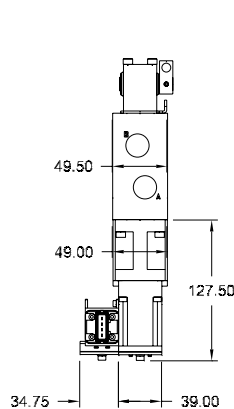

Size 5  
(sandwich style)

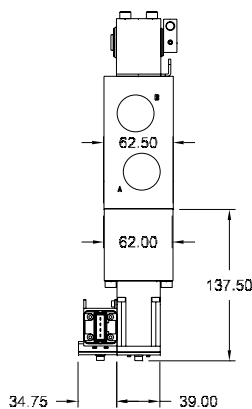

Size 3  
(manifold mounting)

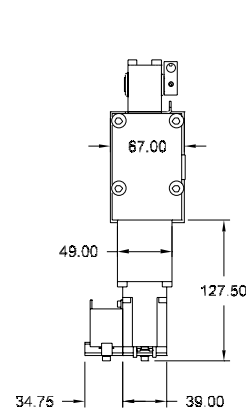

Size 7  
(manifold mounting)

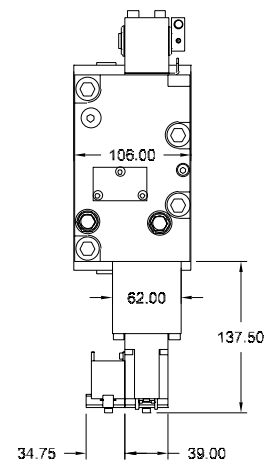

## General parameters and dimensions

	Flow [lpm]		Oper. pressure [bar]	Ports (BSPP)		m [kg]
	$Q_{max}$	$Q_{pu\ max}$	$p_{max}$	P, R	A, B	Per valve section <sup>1)</sup>
PSL/PSV 2	3 ... 54	80	420	G 1/2 3/4-16 UNF-2B	G 3/8, 3-4-16 UNF-2B	1.8 ... 2.9
PSL/PSV 3	3 ... 120	200	420	G 1/2, G 3/4, G 1, 1 1/16-12 UNF-2B	G 1/2, G 3/4, 7/8-14 UNF-2B	3.3 ... 4.1
PSL/PSV 5	16 ... 240	300	400	G 1, G 1 1/4, 1 5/8-12 UN-2B	G 1, 5/16-12 UNF-2B	3.7 ... 4.5

## CAN starter set

The CAN starter set enables communication and functionality of CAN valves from a desk, i.e. without a fully functioning complete hydraulic system.

With the CAN starter set, a PC can be used as a partner for the valve (point-to-point connection to the CAN dongle). However, complete bus system simulations containing several bus nodes can also be run.

### Scope of delivery:

- Electronics module including actuating solenoid
- 4-pin AMP mating connector for adaptation to D-Sub and 4-mm spring connector for power supply
- Data carrier with the HAWE CanNodeTool and drivers

Order coding and item numbers:

- PSX-CAN starter kit: 3405 4200-00
- PEAK CAN USB dongle: 6219 2001-00

A power supply unit for the electric power supply is not included in the scope of delivery. This is required for operation (e.g. 24 V, 1 A).

## End-to-end service.

With five sales offices in the U.S., subsidiaries and expert partner companies throughout North America, HAWE Hydraulik is bound to have a presence in your area.

HAWE Hydraulik offers the following benefits:

- Comprehensive individual advice and assistance
- Customized solutions
- Products designed and manufactured using state-of-the-art technology
- Many years of experience and expertise in hydraulic products and their uses
- Tailored service and maintenance contracts
- Layout, set-up, and maintenance/service on-site

If you have any questions, please get in touch. Our experts are always happy to help.

### HAWE - Charlotte

13020 Jamesburg Drive, Suite A | Huntersville, NC | 28078  
Tel 704-509-1599 | [info@hawehydraulics.com](mailto:info@hawehydraulics.com) | [hawe.com](http://hawe.com)

### HAWE - Portland

12990 S.E. Hwy 212 | Clackamas, OR | 97015  
Tel 503-222-3295 | [info@hawehydraulics.com](mailto:info@hawehydraulics.com) | [hawe.com](http://hawe.com)

### HAWE Hydraulik SE

Einsteinring 17 | 85609 Aschheim/München | Germany  
Tel +49 89 379100-1000 | Fax +49 89 379100-91000 | [info@hawe.de](mailto:info@hawe.de) | [www.hawe.com](http://www.hawe.com)